

A-6. Dimensions

Susol MCCB TE100, 160 series

TE100, 160	A-6-1
------------------	-------

Susol MCCB TD, TS series up to 800A

TD160	A-6-2
TD100, 160	A-6-3
TS100, 160, 250	A-6-4
TS400, 630	A-6-5
TS800	A-6-6

Accessories for TD/TS series up to 800A

Direct rotary handles up to 800AF	A-6-7
Extended rotary handles up to 800AF	A-6-13
Mechanical interlocking device up to 800AF	A-6-19
Plug-in device up to 800AF	A-6-22
Terminal cover up to 800AF	A-6-28
Rear terminals up to 800AF	A-6-30
Extended terminal up to 800AF	A-6-30
Rear terminals up to 800AF	A-6-31
Circuit breaker with motor operator up to 800AF	A-6-37
Wiring connection(motor operator)	A-6-38
Wiring diagram(State of operation)	A-6-39

Susol MCCB TS series up to 1600A

TS1000, 1250, 1600A front type	A-6-40
TS1000, 1250, 1600A front type busbar	A-6-41
TS1000, 1250, 1600A rear type	A-6-42
Rotary handles for TS 1600AF	A-6-43
Locking devices for TS 1600AF	A-6-44
Terminals for TS1600AF	A-6-45

Susol MCCB DC PV series up to 1600A

TD100, TD160, TS100, TS160, TS250	A-6-47
TS400, TS630, TS800	A-6-48
Short BUSBAR	A-6-51
TS1600NA	A-6-54
Short BUSBAR	A-6-57

Overall dimensions

Susol

TS100/160/250

[mm]

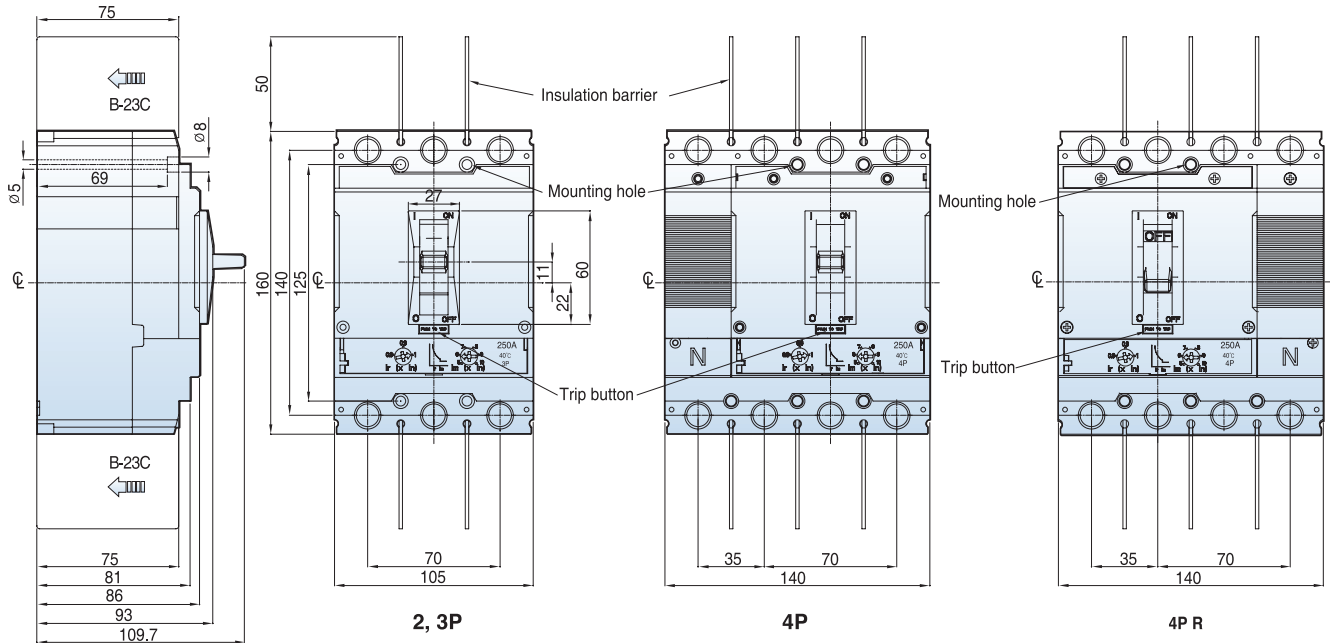

Terminal section

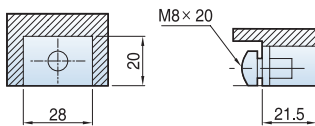

Conductor

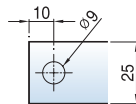

Panel drilling

Front panel cutting

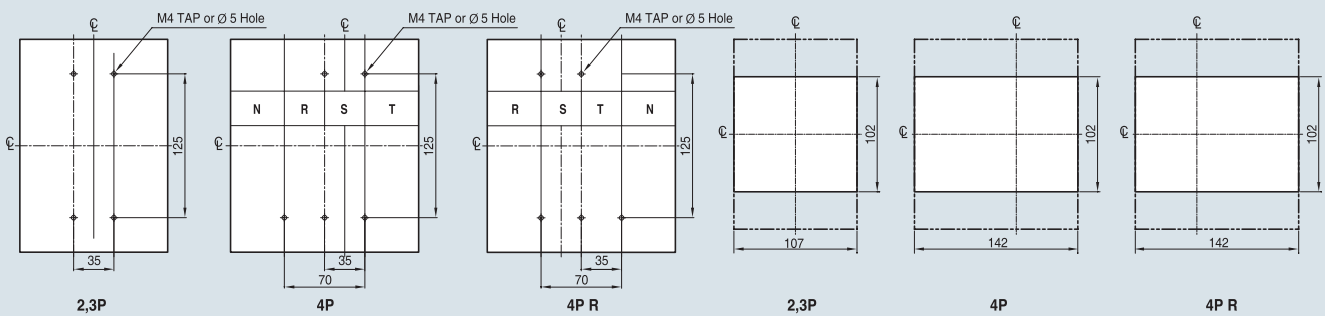

Overall dimensions

Susol

TS400/630

[mm]

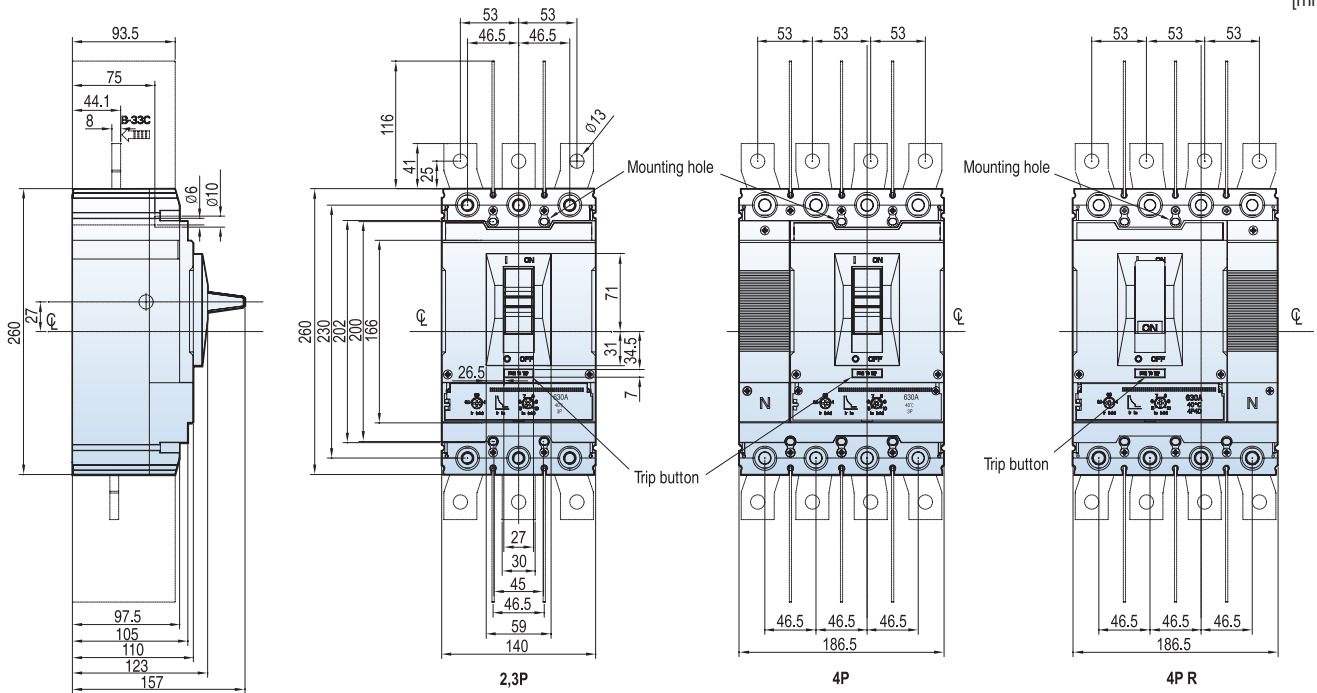

Terminal section

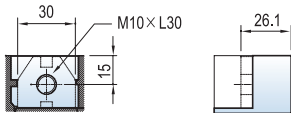

Conductor

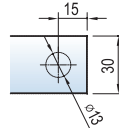

Panel drilling

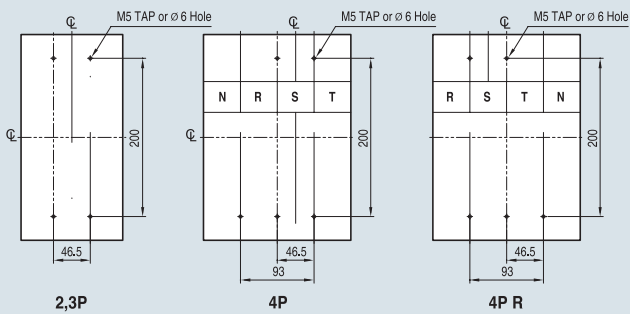

Front panel cutting

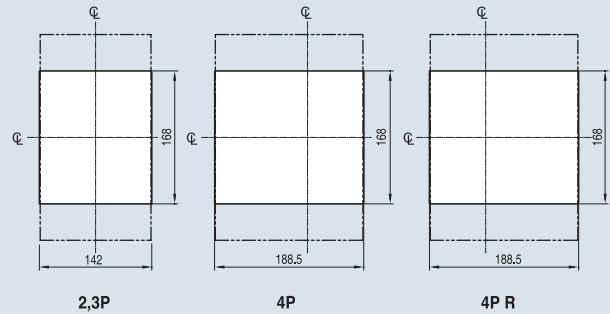

Overall dimensions

Susol

TS800

[mm]

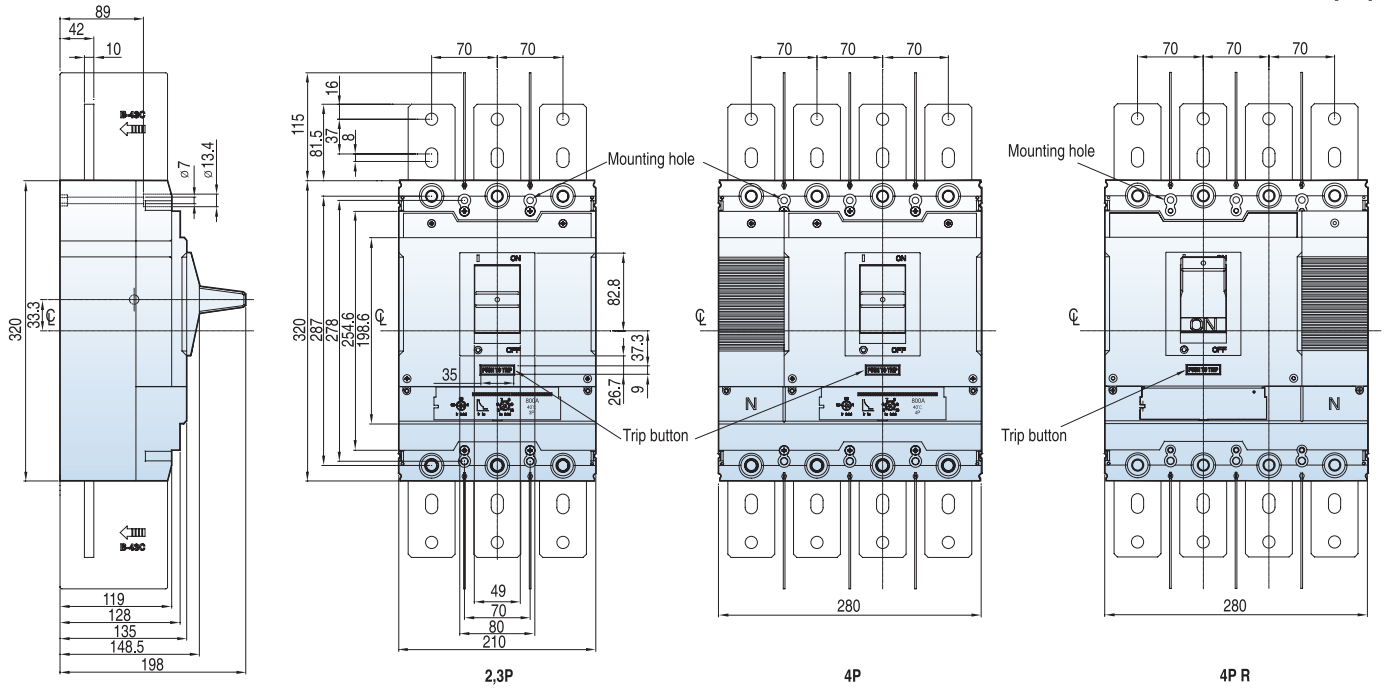

Terminal section

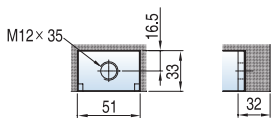

Conductor

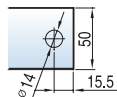

Panel drilling

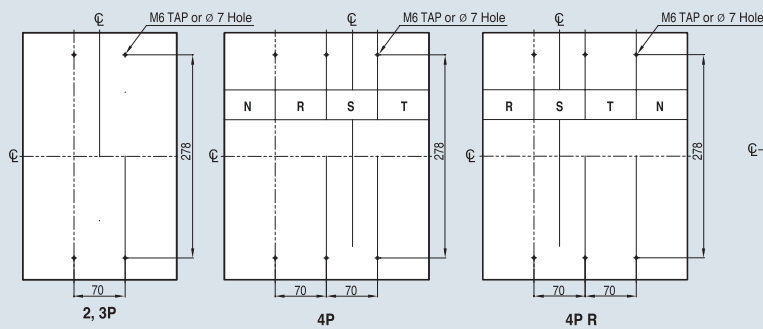

Front panel cutting

